

"Demanded by Those Who Know Quality"

"R" SERIES REPLACEMENT TAILGATE SPREADER

R161-DD, R161-DD-8422, R161-DD-8436, R161-DD-8446, R191-DD-8436, R191-DD-8446

S T A N D A R D F E A T U R E S :

Full-width agitator is driven by a roller chain off the auger shaft

Two hydraulic motor operation - one at the auger and one at the spinner for independent variable speed control.

Direct Drive Auger

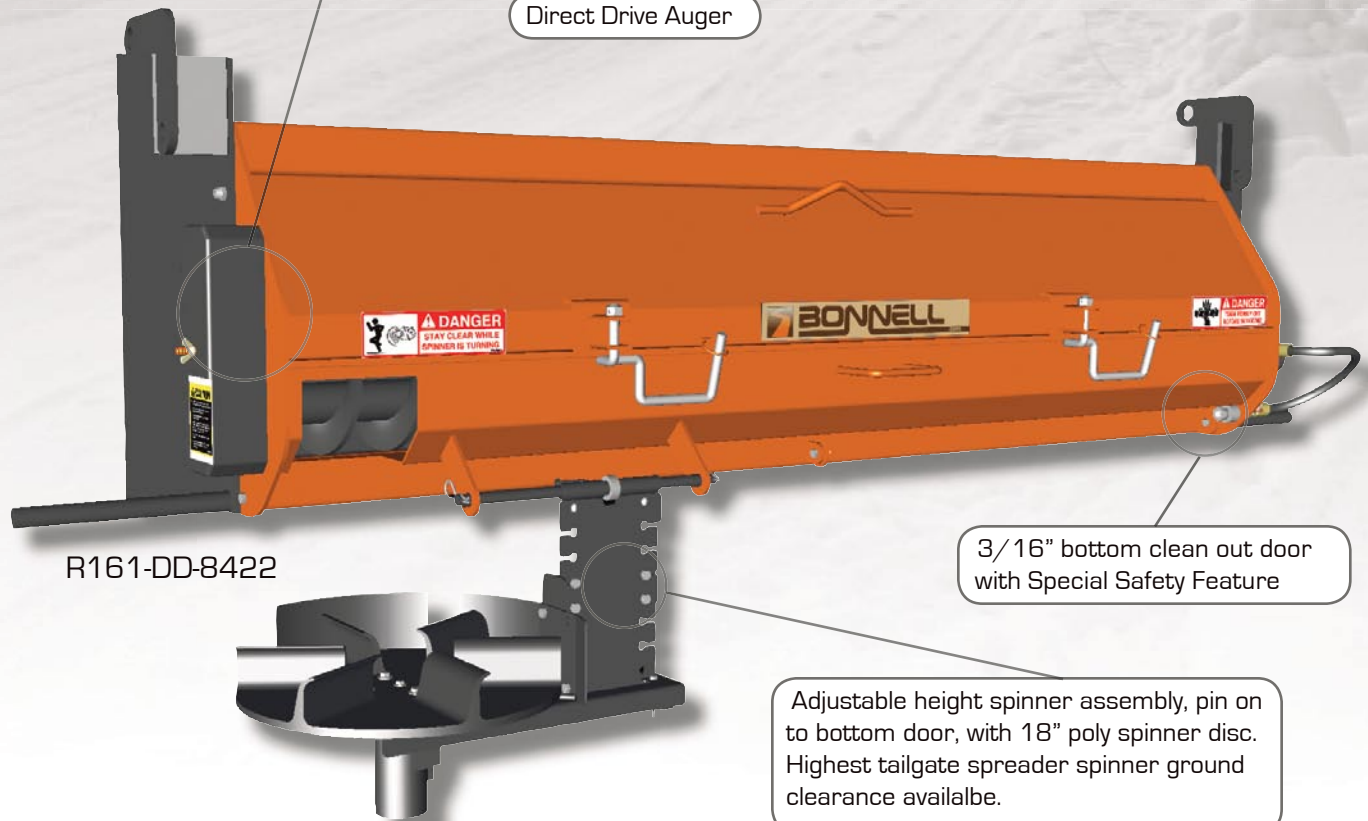

R161-DD-8422

3/16" bottom clean out door with Special Safety Feature

Adjustable height spinner assembly, pin on to bottom door, with 18" poly spinner disc. Highest tailgate spreader spinner ground clearance available.

Replacement Tailgate Spreaders from Bonnell Industries are designed to replace the existing tailgate, providing the highest spinner ground clearance possible. They are engineered for use with light, medium and heavy duty trucks. The hinged bottom cleanout door cannot be fully opened without disconnecting the hydraulic hoses providing the ultimate safety for your operator.

Our auger is driven by a direct drive hydraulic motor. Our full-width agitator is driven by a roller chain off the auger shaft. You can rely on the agitator and 6" or 9" continuous-flited auger

to ensure constant material flow. Both the R-161 and R-191 replacement tailgate spreader models fasten to existing dump body hardware for fast mounting and removal without the use of special tools.

Our standard polymer spinner disc eliminates the need to replace corroded steel fins. The adjustable spinner assembly remains parallel to the road at all dump box angles and can be easily removed by pulling two pins and uncoupling two quick-disconnect hoses.

"R" Series Replacement Tailgate Specifications

Model	Auger	Width	Height
R161-DD	6"	78"	22-1/2"
R161-DD-8422	6"	84"	22-1/2"
R161-DD-8436	6"	84"	36"
R161-DD-8446	6"	84"	46"
R191-DD-8436	9"	84"	36"
R191-DD-8446	9"	84"	46"
		R161	R191
Spinner Diameter/Material		18" polyurethane	18" polyurethane
Trough material		3/16" formed	3/16" formed
End plates		1/4"	1/4"
Auger configuration		1 - 6" dia. x 4" pitch	1 - 9" dia. x 4" pitch
Auger Drive		Direct Drive	Direct Drive



R161-DD-8446-AS



R191-DD-8446

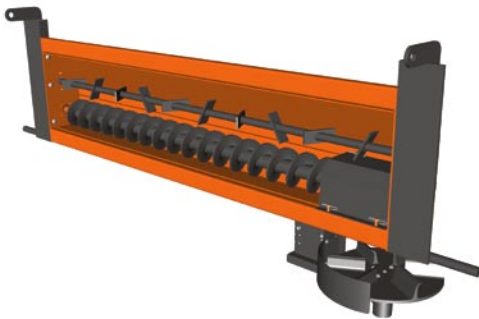

R161-DD-8422



R191-DD-8446

Sold By:



1385 Franklin Grove Rd. • Dixon, IL 61021 • www.bonnell.com
 (815) 284-3819 • (800) 851-9664 • Fax (815) 284-8815

Bonnell Industries reserves the right under its product improvement policy to change construction or design details and furnish equipment when so altered without reference to illustrations or specifications used herein.
 © 2006 Bonnell Industries, Inc. | 0306

Options

- 304 Stainless Steel
- Special Paint
- Berm Chute
- Center, left, or right discharge
- Sensored motor
- Hydro Control Valve
- Hose Kit(s)

