

"Demanded by Those Who Know Quality"

QX HITCH: LOW PROFILE DESIGN

STANDARD FEATURES:

- Universal dual hook-up Quick Attach or Swivel Bar Front Mount
- Offset cylinder for pump clearance
- Compact rigid lift arm with adjustable pick up points
- Available in HFF, UBF, USP and BTA mounting kit
- Fold-up lift arm design

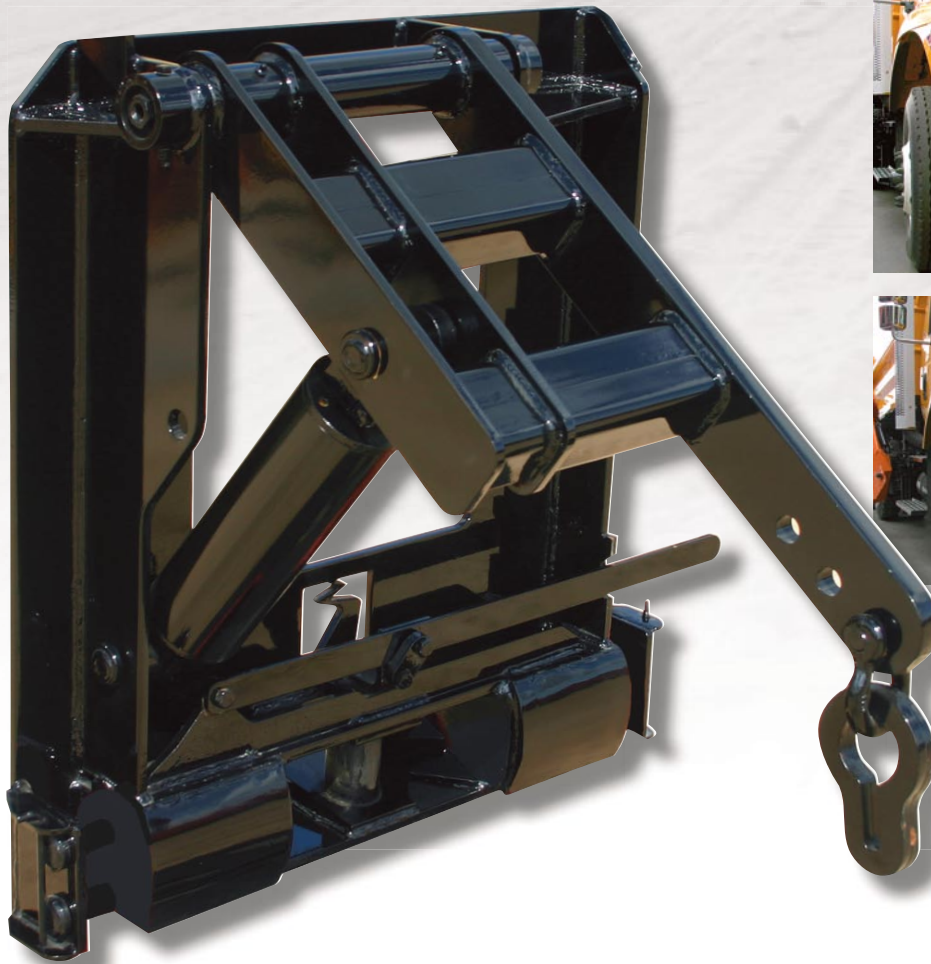

Fig. 1: QX shown in the lowered or down position.

Fig. 2: QX shown in the raised or upper position.

Versatility, safety, and easy operation are all features built into the QX Hitch from Bonnell. This heavy duty hitch features an off center lift cylinder for installation with or without a front mount pump, and is designed to allow the lift cylinder to swing up, and the lift arm to fold down when not in use.

The QX Hitch also comes with a QA receiver welded into position, while at the same time allowing for a swivel bar

type hook up method making it more adaptable to your existing snowplow fleet while keeping the plow as close to the front axle as possible.

Optional mounting kits available:
Custom Side Plate (HFF), Universal Bumper to Frame (UBF), Universal Side Plate (USP) and Bumper to Axle (BTA).

QX Hitch Specifications

Sturdy 1/2" plow frame uprights, low profile design

Fold-up lift arm with stow away lift cylinder

Side-by-side offset lift arm for use with front mounted pto pump.

1-15/16" greasable lift arm pin.

Heavy duty 1" x 4" lift arm, reinforced with 1/2" plate and 4" x 3" x 3/8" tubing. Lift arm will have 3 hook up holes for optional lift points. Standard Bonnell Quick attach receiver with 2-1/2" diameter steel coupling pin welded into frame

Standard Bonnell Drivers side QA sure lock latch lever



Heavy Front Frame (HFF)

- Custom fit 1/2" thick A-36 side plates (5/8" plate optional)
- Minimum (7) 5/8" Grade 8 bolts & lock nuts per side
- Easy to install tow hook-holes are pre-drilled



Universal Bumper to Frame (UBF)

- Heavy duty 1" x 4" push arms
- Universal frame mount Z-Iron brackets

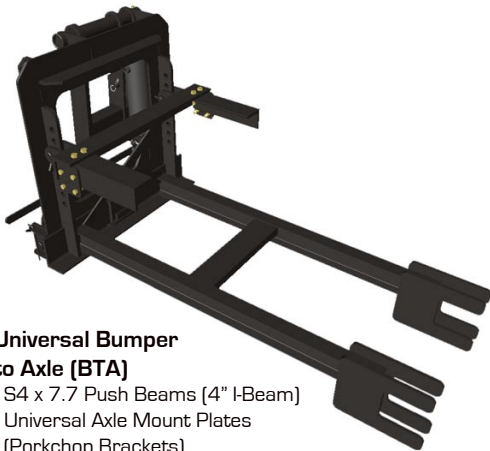

Universal Bumper to Axle (BTA)

- S4 x 7.7 Push Beams (4" I-Beam)
- Universal Axle Mount Plates (Porkchop Brackets)
- Quickly removed from truck with the pull of two pins



Universal Side Plate (USP)

- Heavy duty universal 5/8" side plates
- Universal frame mount Z-Iron brackets

Options

Light Bracket Options

- Grill Mount Certain Models Only
- Hood Mount



Cylinder Options

- 4" x 10" Double Acting
- 4" x 10" Double Acting Nitrated

Other Options

- Cushion Valve
- Bumper Boxes
- Channel Bumpers

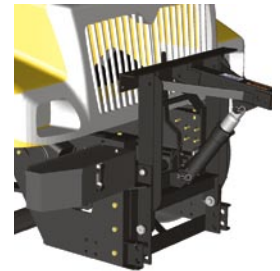

Sold By:



1385 Franklin Grove Rd. • Dixon, IL 61021 • www.bonnell.com
 (815) 284-3819 • (800) 851-9664 • Fax (815) 284-8815

Bonnell Industries reserves the right under its product improvement policy to change construction or design details and furnish equipment when so altered without reference to illustrations or specifications used herein.
 © 2006 Bonnell Industries, Inc. | 0306

