

*"Demanded by Those Who Know Quality"*

# LEVEL RAISE LIFT SYSTEM™

US PATENT 7,017,288

S T A N D A R D F E A T U R E S :

Top mounted with no mechanism underneath the table

Uses all rotating mechanisms which greatly limits the possibility of binding

More leveling capability and workability with different types of hitch/lift combinations

Level lift on most trucks

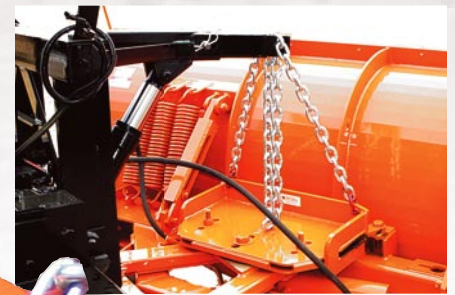
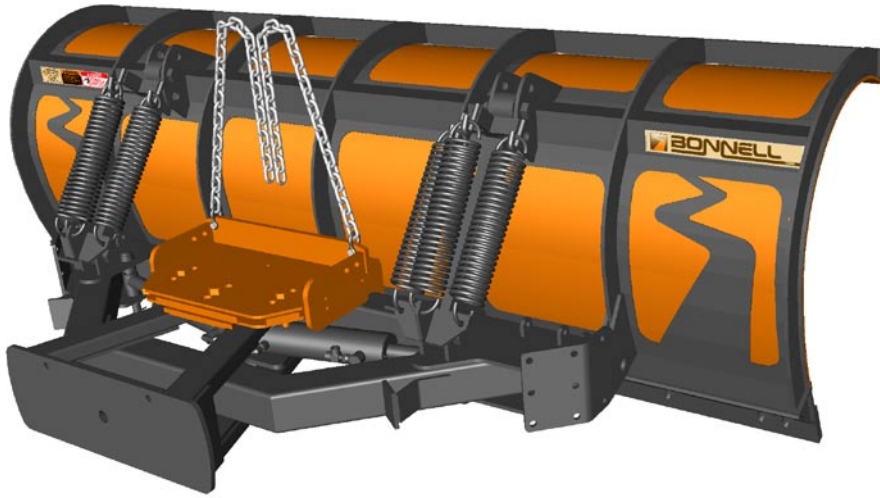

Fig. 1: Can be set in any of 3 sets of holes enabling different degrees of leveling capability, increasing the workability with different types of hitch/lift arm combinations

The Level Raise Lift System™ allows snowplow cutting edges to remain parallel to the road surface at all times regardless of the angle of the moldboard.

The Level Raise Lift System™ is available on all new Bonnell High Country, Metropolitan and Utility snow

plows. This lowcost feature reduces damage to the moldboard or cutting edge of the plow due to a low corner striking the ground. This enhancement promotes added safety for the operator while reducing maintenance from undue "wear and tear" of vehicles and snowplows that do not raise level.



High Country Series

Utility Series

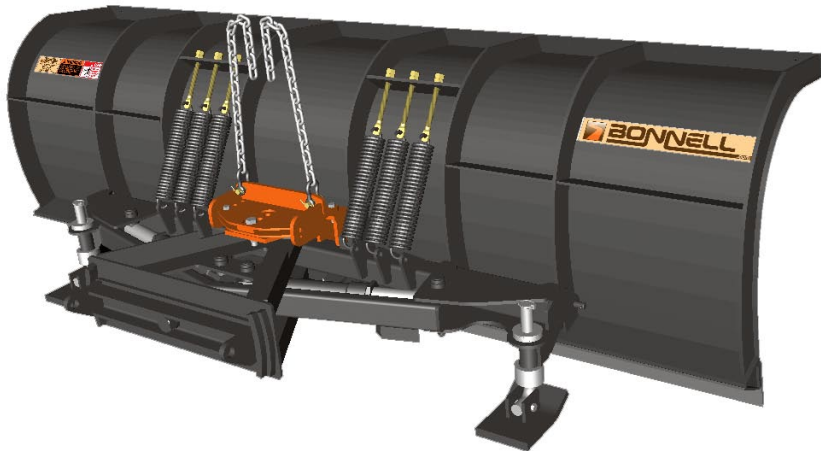

By shifting the positions of the chain hook-up points on the plow using the Level Raise Lift System™, the table pin-up points and moldboard cutting edge remain parallel to the ground.



Reversed to Right



Bulldoze



Reversed to Left

Sold By:



1385 Franklin Grove Rd. • Dixon, IL 61021 • www.bonnell.com  
 (815) 284-3819 • (800) 851-9664 • Fax (815) 284-8815

Bonnell Industries reserves the right under its product improvement policy to change construction or design details and furnish equipment when so altered without reference to illustrations or specifications used herein.  
 © 2006 Bonnell Industries, Inc. | 0306

