

*"Demanded by Those Who Know Quality"*

# HIGH COUNTRY TORSION TRIP SNOW PLOW

Available with All High Country and Metropolitan Snow Plows

## STANDARD FEATURES:

5" x 5" x 3/8" HD Square Tube Table, 90" wide Push Frame, and Massive 3-1/2" Round Pivot Bushing

[5] Table to Moldboard Hook-Up Points with 1-1/2" Thick Ribs, 3" Bearing Surface and 1-1/4" Pins

Extended Roll Moldboard Continuously Welded

[3] Adjustable Pitch Settings

[2] 1" x 2-1/2" Trip Connecting Posts - fastened by 1-1/4" Bolts.

[4] 3/4" Diameter Spring Wire Torsion-Trip Springs - Independently Replaceable, 7/8" optional

Deep "C" A-Frame

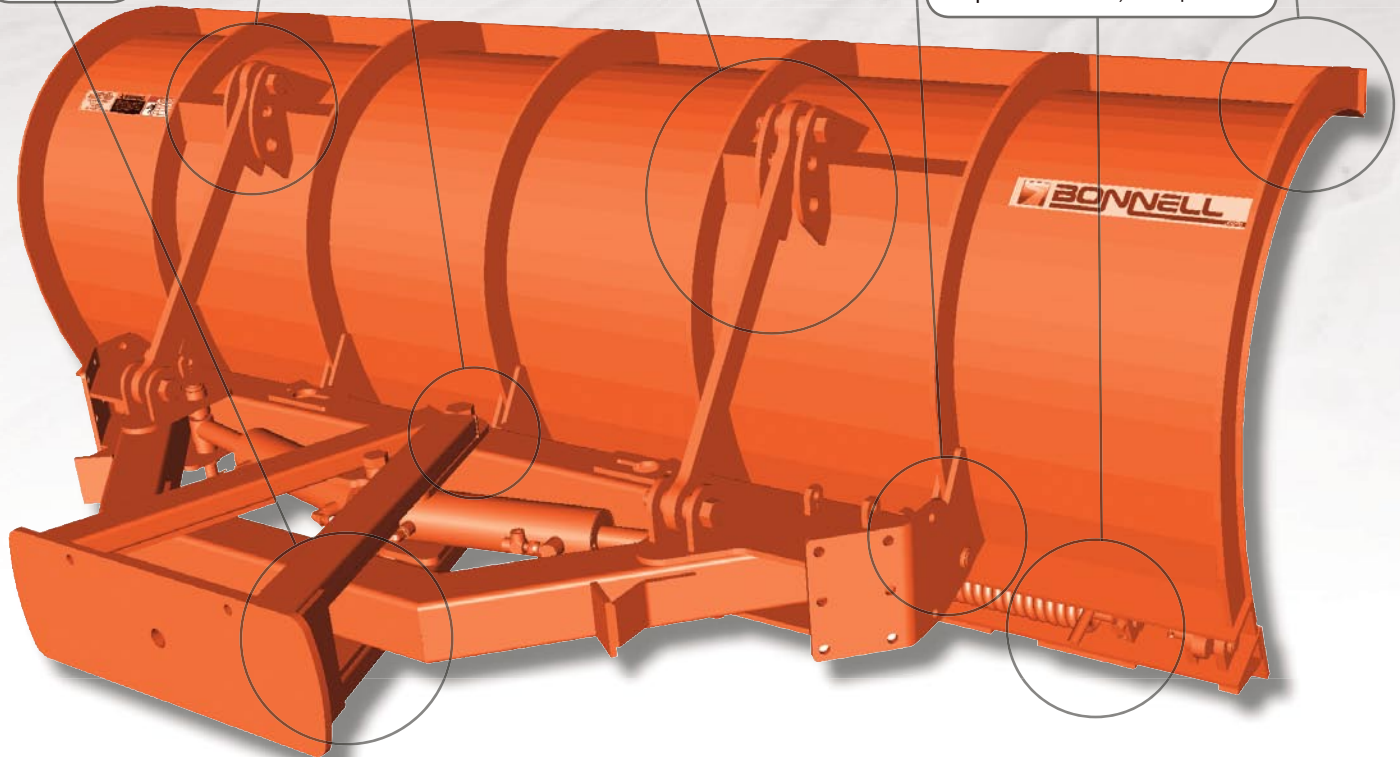

Bonnell High Country Torsion Trip Snow Plows are designed for removing snow at high-speeds in rural areas and interstate highways. The standard extended roll moldboard is designed to move the snow to the discharge end of the plow more efficiently. This prevents the snow from blowing over the top of the plow.

Bonnell's many standard features are what set us apart from our competition. Our torsion-trip cutting edge is designed with [4] 3/4" spring wire torsion trip springs, each of which are independently replaceable without removing other springs or hinge pins. The moldboard has [3] adjustable pitch settings,

allowing you to regulate the attack angle of the cutting edge. The lower reinforcing angle has [5] hinge ears welded along its bottom provided for attaching the trip lower trip section.

Plows are available with steel or poly moldboards. Other options are also available (see page 2).

Meeting the demands of Mother Nature in the winter is a tough job. You need a tough plow to get you through the harshest conditions. Bonnell High Country series snow plows will clear the way.

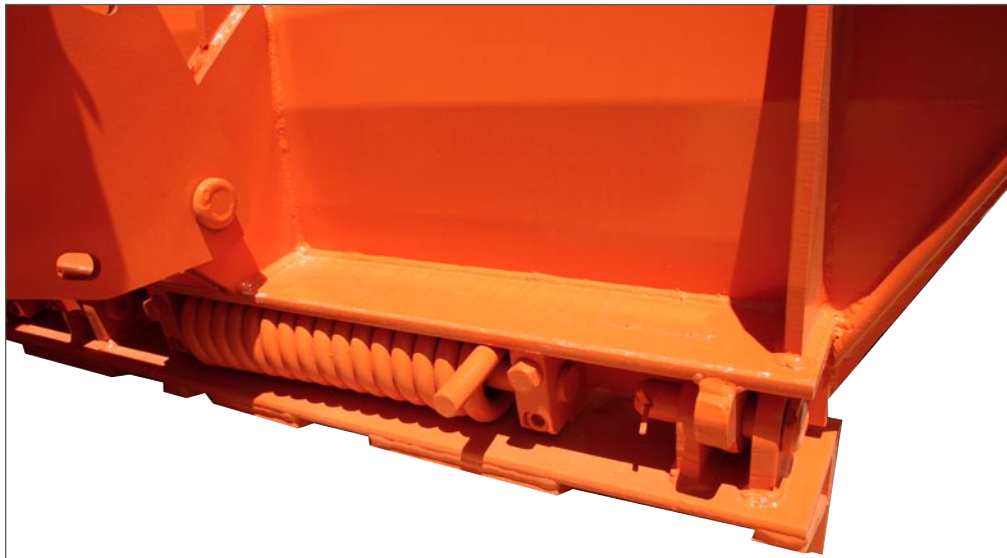

Spring Wire Diameter: 3/4" (7/8" optional)

Number of Springs: 4

Adjustable Moldboard Pitch Settings: 25°, 15° or 5° off vertical

Lower Reinforcement Angle: 4" x 4" x 1/2"

Trip Angle: 5" x 3" x 1/2" reinforced with 1/2" plate gussets

Trip Pin Diameter: 1-1/4"

For complete plow specifications see literature on specific model.

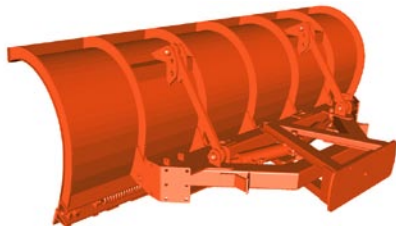

High Country Straight

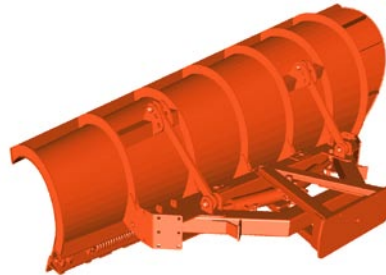

High Country Tapered



High Country Distant Discharge



Metropolitan Straight, Tapered and Distant Discharge

Sold By:

## High Country Options

### Plow Lift Options

- Chain
- Level Raise Lift System™
- Chain and Saddle
- Cable Wrap



### Plow Hook-Up Options

- Quick Attach Loop
- Swivel Bar with Push Ears (1-1/4" pins @ 30.5")
- Husting Style
- Custom Application



### Running Gear Options

- Standard-Duty Mushroom Shoes
- Heavy-Duty Mushroom Shoes
- Heavy-Duty Even Wear Shoes
- Carbide Even Wear Shoes
- 10" Steel Caster (Kingpinless) Wheels
- 5.70 x 8.0 Pneumatic Tires\*
- Foam-Filled Rubber Tires\*



\*Should not be used with Cable Wrap Lift Assemblies

### Moldboard Options

- 3/4" Bottom Angle
- 7-Gauge Steel Construction
- Curb Cut (Mailbox Cut)
- Extra Ribs
- UHMW Poly Construction
- Special Sizes Available

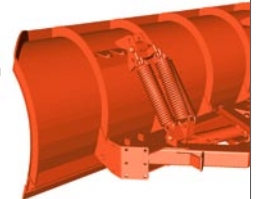

### Tripping Options

- Extension Trip Moldboard
- Compression Trip Moldboard
- Torsion Trip Cutting Edge
- Dual Trip Moldboard & Cutting Edge

### Table Options

- Extended Push Frame
- Manual Reverse
- Power Reverse

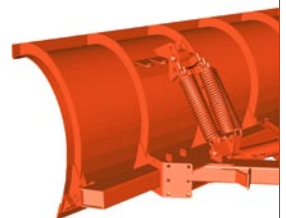

### Cutting Edge Options

- High Carbon Steel
  - Rubber
  - UHMW Poly
  - Carbide Insert with Cover Blade
  - Flame Hardened
  - Joma Black Cat Blades
- All cutting edges available in various sizes

### Other Options

- Cushion Valve
- Curb Shoes
- Blade Savers - Carbide
- Blade Guides
- Rubber Deflector
- Plow Stand
- Nitrited Cylinders
- Extra Extension Trip Springs

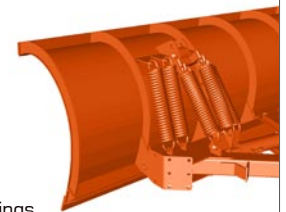

### Paint Options

- Special Paint Available



1385 Franklin Grove Rd. • Dixon, IL 61021 • www.bonnell.com  
(815) 284-3819 • (800) 851-9664 • Fax (815) 284-8815

Bonnell Industries reserves the right under its product improvement policy to change construction or design details and furnish equipment when so altered without reference to illustrations or specifications used herein.  
© 2006 Bonnell Industries, Inc. | 0306

